

**QuickSpot<sup>®</sup>**

**Walter - WiFi/BLE/NB-IoT/LTE-M module**

Preliminary Datasheet

Preliminary

## 1 General information

Walter is an ESP32-S3 based IoT board that offers WiFi, Bluetooth 5 (LE), cellular CAT M1/NB1/NB2 and GNSS connectivity.

## 2 Features

Walter is based on an ESP32-S3-WROOM-1-N16R2 module with an on-board Sequans GM02SP modem. This combination makes Walter a unique development board that offers a rich feature-set which include but is not limited to:

- CPU: Xtensa Dual-core 32-bit LX7 CPU (ESP32-S3 SoC)
- RAM: 2MB (Quad SPI) PSRAM
- Flash: 16MB (Quad SPI) Flash memory
- WiFi: 150Mbps(n) 802.11 WiFi b/g/n with on-board antenna
- LTE: CAT M1/NB1/NB2 (GM02SP module)
- GPS: GPS, GNSS Constellation support (GM02SP module)
- Bluetooth: 2Mbps Bluetooth 5 (LE), Bluetooth Mesh
- 24 physical GPIO pins

## 3 Electrical characteristics

For the most reliable use and stability of the module we advice to use the typical ratings. We do not guarantee the correct functioning of the device outside the minimum and maximum range of the module.

Parameter	Units	Minimum rating	Typical rating	Maximum rating
DC Supply Voltage	V	3.0	5.0	5.5
Digital I/O Voltage	V	2.64	3.3	3.6
Power consumption @3.3V	A	–	–	1.5
3.3V output	A	–	–	0.25

## 4 Interfaces

Walter provides a total of 28 physical pins (3 power, 1 strapping pin and 24 I/O pins) to interface with external parts. This chapter provides information about these pins as well as internally connected pins and the testpoints located at the bottom of the board.

Power supply pins and their details are available in section 5.1 about the power characteristics.

For more information about specific pins regarding the ESP32-S3 Wroom module or the Sequans GM02SP module, please refer to the datasheet of the corresponding module.

### 4.1 Pin Assignment

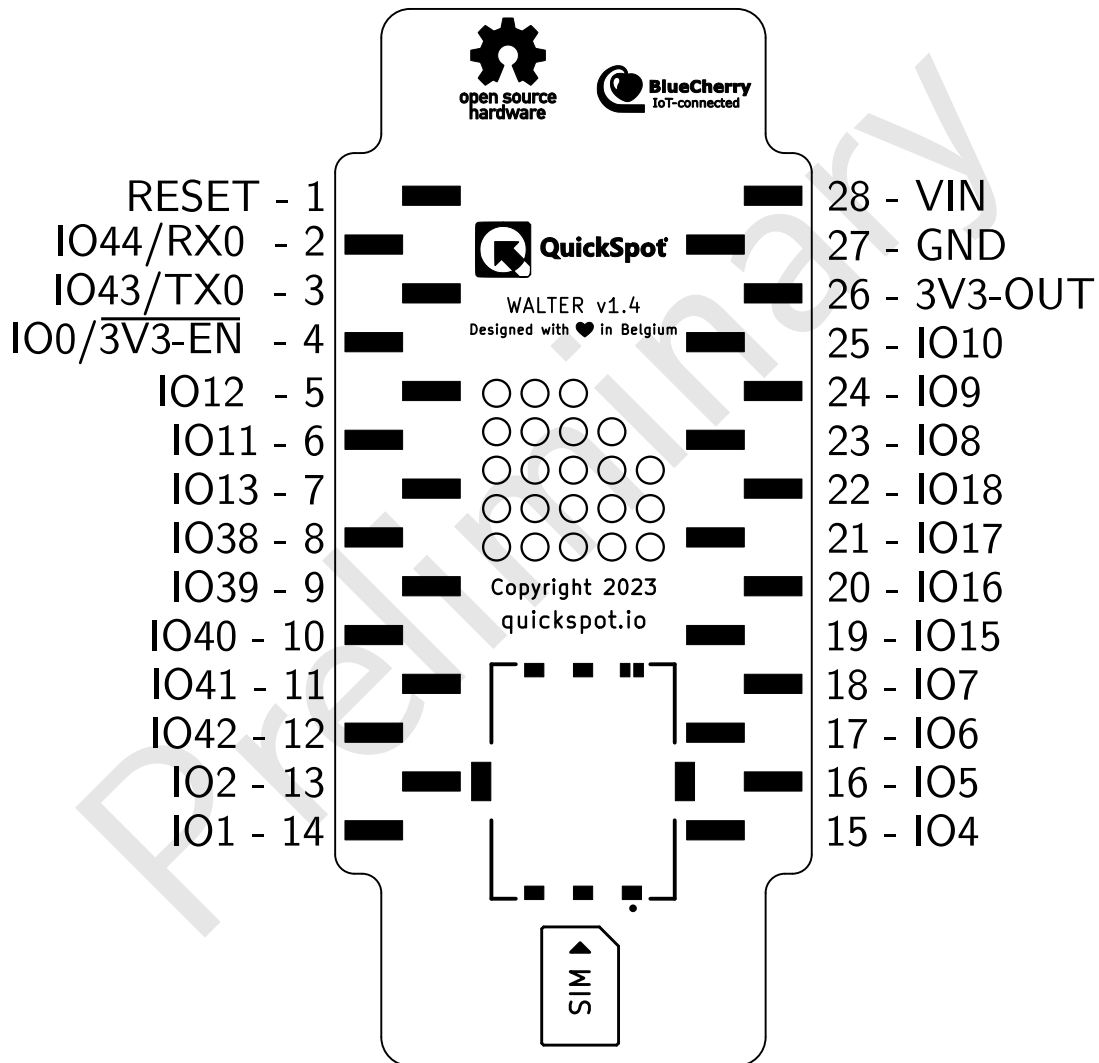

Figure 1: Walter pinout (top view)

4.1.1 External Pins

Table 1 contains the description of the physical pins on Walter available on the underside of the board. The order of this table, in reference to the board, is top to bottom and left to right.

Pin	Function	ESP pin	Input/Output	Description
1	RESET	EN	input	ESP32 reset with 10k pullup
2	IO44/RX0	RXD0	bidirectional	ESP32 UART0 Receive
3	IO43/TX0	TXD0	bidirectional	ESP32 UART0 Transmit
4	$\overline{\text{DFU}}/\overline{3\text{V}3\_EN}$	IO0	bidirectional	DFU when low on boot and 3V3 output enable
5	IO12	IO12	bidirectional	General purpose I/O
6	IO11	IO11	bidirectional	General purpose I/O
7	IO13	IO13	bidirectional	General purpose I/O
8	IO38	IO38	bidirectional	General purpose I/O
9	IO39	IO39	bidirectional	General purpose I/O
10	IO40	IO40	bidirectional	General purpose I/O
11	IO41	IO41	bidirectional	General purpose I/O
12	IO42	IO42	bidirectional	General purpose I/O
13	IO2	IO2	bidirectional	General purpose I/O
14	IO1	IO1	bidirectional	General purpose I/O
15	IO4	IO4	bidirectional	General purpose I/O
16	IO5	IO5	bidirectional	General purpose I/O
17	IO6	IO6	bidirectional	General purpose I/O
18	IO7	IO7	bidirectional	General purpose I/O
19	IO15	IO15	bidirectional	General purpose I/O
20	IO16	IO16	bidirectional	General purpose I/O
21	IO17	IO17	bidirectional	General purpose I/O
22	IO18	IO18	bidirectional	General purpose I/O
23	IO8	IO8	bidirectional	General purpose I/O
24	IO9	IO9	bidirectional	General purpose I/O
25	IO10	IO10	bidirectional	General purpose I/O
26	3V3 OUT	N/A	power output	Switchable 3.3VDC output
27	GND	GND	power ground	GND connection
28	VIN	N/A	power input	DC Power input port

Table 1: Walter pin definitions

#### 4.1.2 Internal Pins

Table 2 contains the pin descriptions of the internally connected GPIO pins on Walter. These are necessary for either communication between components on the board or reserved for other purposes and thus not available for external use.

ESP pin	Description
IO19	USB D-
IO20	USB D+
IO46	LTE_WAKE0
IO48	LTE_UART0_TX (See 4.2)
IO14	LTE_UART0_RX (See 4.2)
IO21	LTE_UART0_RTS (See 4.2)
IO47	LTE_UART0_CTS (See 4.2)
IO45	LTE_RESET

Table 2: Walter Internal Pin Definitions

### 4.1.3 Testpoints

Walter contains 22 testpoints on the bottom of the board that serve multiple purposes. You can use these pins for debugging, interfacing and/or flashing of the Sequans GM02SP and the ESP32-S3-WROOM module.

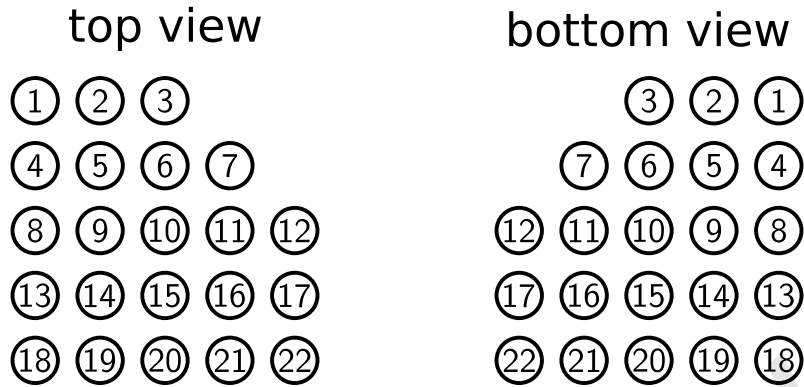

Figure 2: Walter testpoints

Number	Description
1	Sequans GM02SP JTAG TDO
2	Sequans GM02SP JTAG TCK
3	Sequans GM02SP JTAG TRSTN
4	Sequans GM02SP JTAG TMS
5	Sequans GM02SP JTAG TDI
6	Sequans GM02SP PS status
7	Sequans GM02SP RES/FFF_FFH
8	Sequans GM02SP RX0
9	Sequans GM02SP TX0
10	Sequans GM02SP TX1
11	Sequans GM02SP RX1
12	Sequans GM02SP RX2
13	Sequans GM02SP CTS0
14	Sequans GM02SP RTS0
15	Sequans GM02SP CTS1
16	Sequans GM02SP RTS1
17	Sequans GM02SP TX2
18	Walter input power
19	3V3 output (not switched)
20	Sequans GM02SP 1V8 output
21	Ground
22	ESP32-S3 GPIO3 (strapping pin)

## bottom view

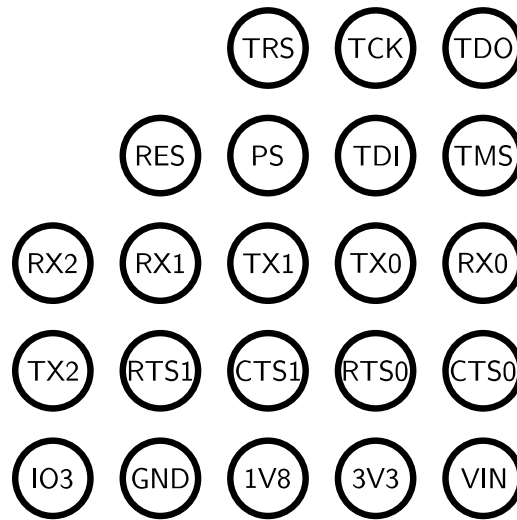

Figure 3: Bottom view of the Walter testpoints with their connection names.

### 4.1.4 Others

Not all pins of the ESP32-S3 and Sequans GM02SP on Walter are internally connected, available through physical pins or testpoints. These pins are either reserved for use by the component itself or deemed not necessary to be available externally.

## 4.2 Sequans GM02SP UARTs

The Sequans GM02SP module has 3 hardware UART interfaces. Only UART0 is connected to the ESP32-S3 Wroom Module on Walter as shown in Table 2. Communication between modules is possible with AT-commands. Please refer to the corresponding AT command reference manual of the Sequans GM02SP for all possible AT-commands. The UARTs have the following functionality by default:

- UART0 (115200@8N1 with HW handshaking): used for AT commands.
- UART1 (921600@8N1 with HW handshaking): used for manual firmware updates and/or custom software installation.
- UART2 (115200@8N1 no HW handshaking): console log output.

Please note that any UART host should be connected as follows:

- RX <-> RX
- TX <-> TX
- RTS <-> RTS
- CTS <-> CTS

## 5 Electrical and RF Characteristics

### 5.1 Power

#### 5.1.1 Power Input

Walter can be powered either by connecting a USB-C cable or via the VIN pin (see pinout 4.1.1).

**DO NOT** power Walter with both the USB-C connection and the VIN-pin! This can lead to seriously damaging the board and external peripherals connected to it!

### 5.1.2 Power Output

Walter contains a Texas Instruments LM3281YFQR DC-DC Converter which takes power from either the USB-C port or the VIN-pin and converts it to a regulated +3.3VDC supply.

### 5.1.3 Power Consumption

## 5.2 GPIO

All GPIO pins exposed via the physical pin headers on Walter are 3.3V resistant. If you want to connect 5V or other forms of logic, please use a suitable logic level converter or voltage divider.

Please reference the corresponding datasheets for all minimum, maximum and typical ratings of I/O pins of the ESP32-S3-WROOM or Sequans GM02SP Modules that may or may not be exposed on the Walter Development Board.

Preliminary



## 6 Mechanical information

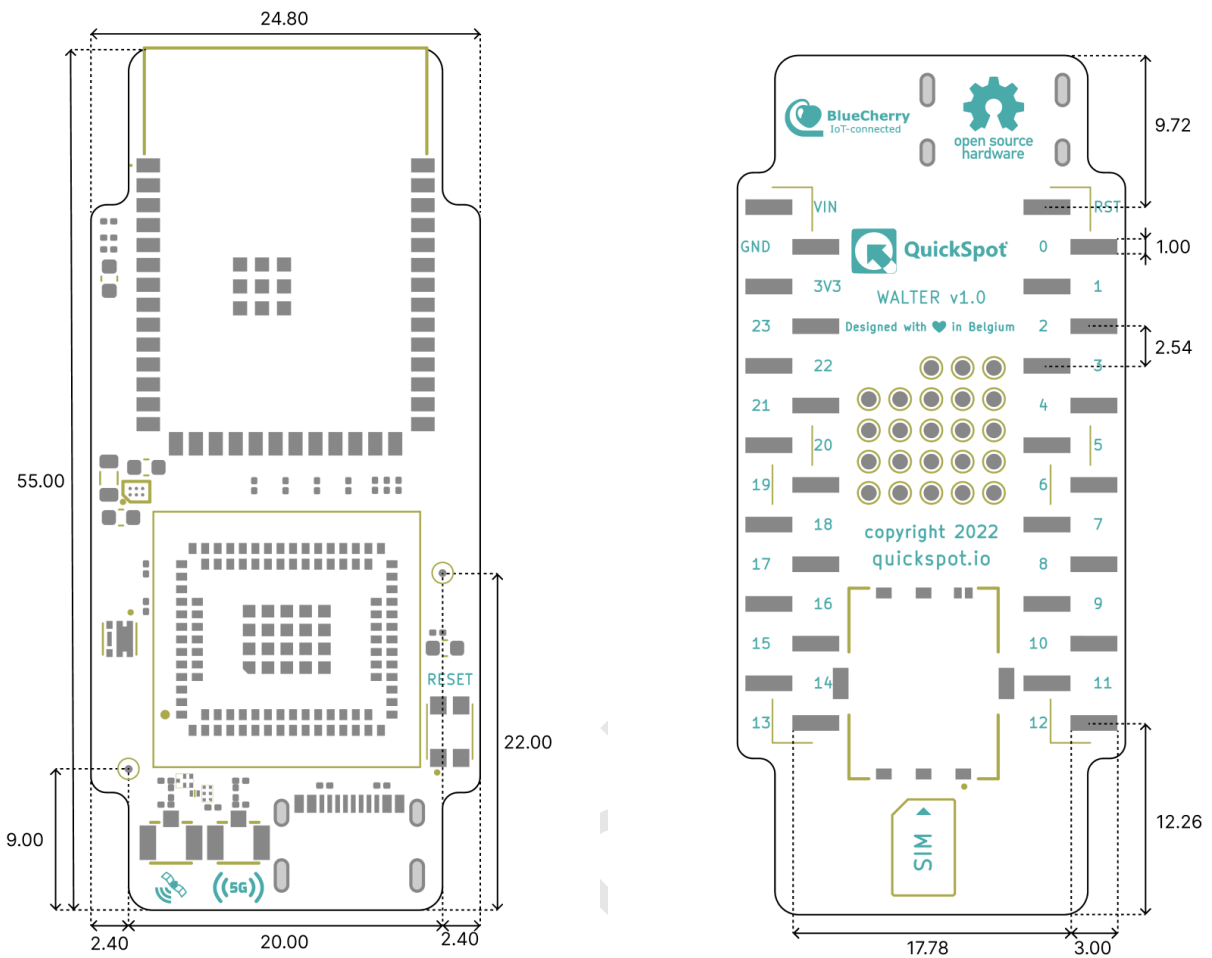

Figure 4: Mechanical Drawing Front and Rear View - Unit in mm

## 7 Software

### 7.1 Libraries and frameworks from QuickSpot

Walter comes without firmware out of the box. You can easily program and upload your own firmware for Walter using MicroPython, Arduino, ESP-IDF... Please refer to the "Getting Started with Walter" available on our GitHub to get you up and running fast.

### 7.2 AT commands

The full set of supported AT commands can be found in the documentation of the Sequans GM02SP. This can be downloaded from this link: <https://www.renesas.com/eu/en/document/mah/ryz024-modules-command-users-manual?language=en>.

### 7.3 Manual SFU of the GM02SP

The second hardware UART of the GM02SP, namely UART1, is used for manual firmware upgrades. To do a manual serial SFU of the GM02SP in Walter you must connect UART1 via the testpads on the bottom of the module. Use an FTDI UART and make the following connections:

- Walter RX1 <-> FTDI RX

- Walter TX1 <-> FTDI TX
- Walter RTS1 <-> FTDI RTS
- Walter CTS1 <-> FTDI CTS
- Walter GND <-> FTDI GND
- Walter Vin <-> +5VDC

Make sure that the 5V power source which is powering Walter and the FTDI share a common ground. To enable smooth updating it is best not to connect the USB-C on Walter to the computer on which the SFU software is running. Now follow the instructions which are bundled with the SFU release.

## 8 Operating conditions

The module can operate in a wide range of temperatures and conditions. The following are guidelines in which the module is guaranteed to work correctly.

Parameter	Units	Minimum rating	Typical rating	Maxium rating
Working temperature	°C	-40		85
Storage temperature	°C	-40		100
Humidity	%RH	10		90
Storage humidity	%RH	5		90

Please note that no condensation may occur on the PCB and components.

## 9 Legal information

This module is distributed worldwide by DPTechnics bv. We are not responsible for any product this module is part of. This datasheet is made with great care for detail but it can be possible the datasheet will be updated with more accurate data in te future. Users of DPTechnics bv products can contact us by letter, telephone or email.

DPTechnics bv  
Westkapellestraat 396/44  
8300 Knokke-Heist  
Belgium

Tel: +32(0)50 62 13 79  
email: [info@quickspot.io](mailto:info@quickspot.io)  
web: <https://www.quickspot.io>